

SHARE

FOCUS POD COLLECTION

Designed by Christopher Metcalfe
for IQ Commercial



SPECIFICATIONS SHEET

SHARE by IQ COMMERCIAL



Dimensions

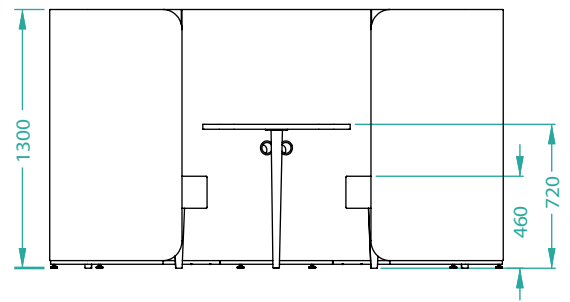
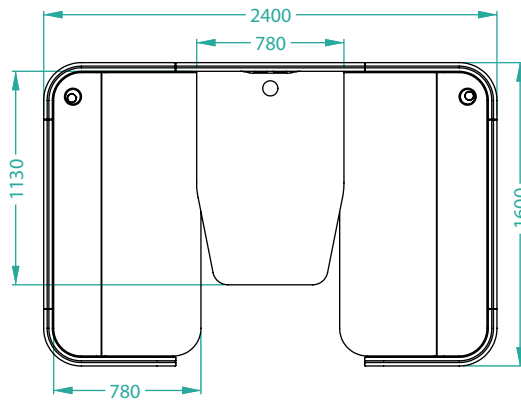

About

Designed by Christopher Metcalfe and developed in collaboration with award winning firm Revolution Fibres, the Share Pod features Phonix™ nanofibre as an acoustic substrate designed to enhance the absorptive features of the soft walls. The Share Pod is designed to increase productivity in today's open office spaces. The sixth design in the series, the Share Pod provides a flexible work zone for informal catch-ups, client meetings, brainstorming and easier connection with co-workers. It has the flexibility to be configured to any size of space, to include a desk and chair, add a media screen or other technology and the power and USB charge points come standard. Internally routed cable management facilitates power and data solutions built into the work surface.

Specifications

Worktop included: Melteca, 15mm rebate standard, plus scallop cut for cable to pass through.
 Worktop colours: Snowdrift, Seal Grey, Tawa, Teak.
 Includes the exclusive Phonix™ Nano Fibre acoustic substrate.
 Frame: FSC Radiata ply, water based glues.
 Foam: High resilience, commercial grade.
 Prices include packaging.
 Power Data includes the base unit and an interconnect cable; starters may be required to be sourced locally.
 Power Data: internal routing provided; assumes floor sourced power connection.

PRODUCT DIMENSIONS AND SHIPPING INFORMATION

LENGTH (mm)	2400
HEIGHT (mm)	1300
DEPTH (mm)	1600
SHIPPING VOLUME	TBA
WEIGHT (KG)	230kg Excluding Crate
VOLUME WITH LCL PACKAGING	TBA

FABRIC METERAGES Fabric (Plain RR) INSIDE 9 OUTSIDE 9 SEAT 8

WORKTOP FINISH OPTIONS

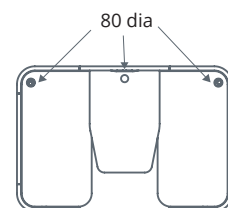

3x Power, 3 x Provision for Data, 3x USB Charge

Elsafe Pixel

