

Dynamic Monitor Arm & Notebook Tray on 135 Post

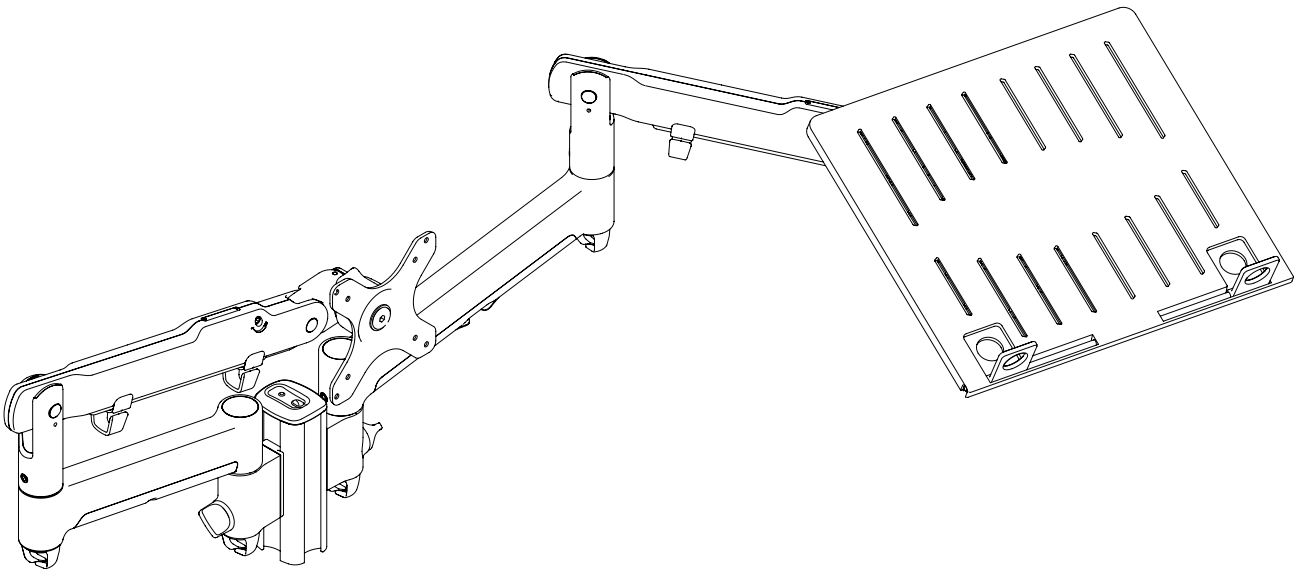

FEATURES

- A notebook and dynamic arm combination, ideal for activity based workplaces.
- Easy to install and re-configure with monitor quick release/attachment mechanism.
- Integrated 180° rotation limiter to prevent interference with desk mounted panels and dividers.
- Generous cable management guides cables discreetly down the arm to the work surface.

Monitor weight range

Flat monitor

0-9kg (0 - 20lb)*

Curved monitor

0-6kg (0 - 13.5lb)*

Notebook weight range

0-8kg (0 - 18lb)

Vertical Adjustment

368mm (14.49")

Tilt angle

+45 /- 25°

Monitor rotation

360°

VESA mounting

75x75 | 100x100

*Monitor weight should be within the weight range of all modular elements that make up the complete monitor mounting solution.

*Curved monitors, deep devices (such as all-in-one PCs) and offset VESA locations exert additional leverage that can exceed the capacity of the mount even though the monitor weight may be within the stated range. Please contact Atdec if you would like further information.

WARRANTY

10 years limited

PLAN VIEW

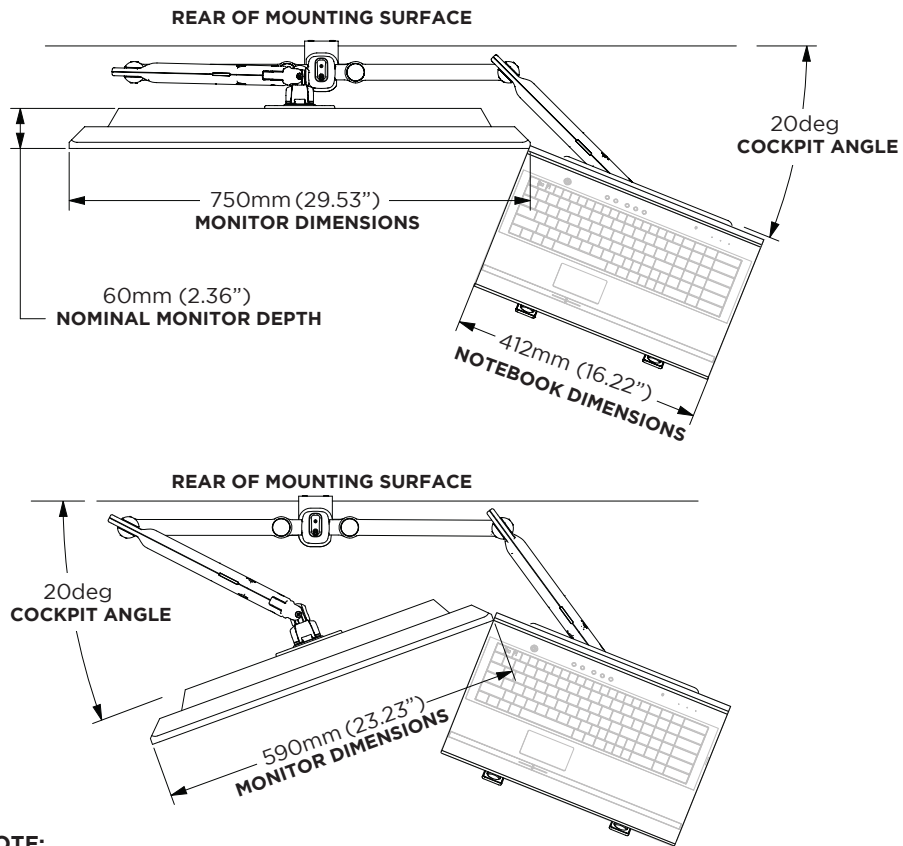

NOTE:
DIMENSIONS ILLUSTRATED ARE REPRESENTATIVE
OF AN INDICATIVE SETUP AND ARE SUBJECT TO
CHANGE

MOVEMENT - DYNAMIC ARM

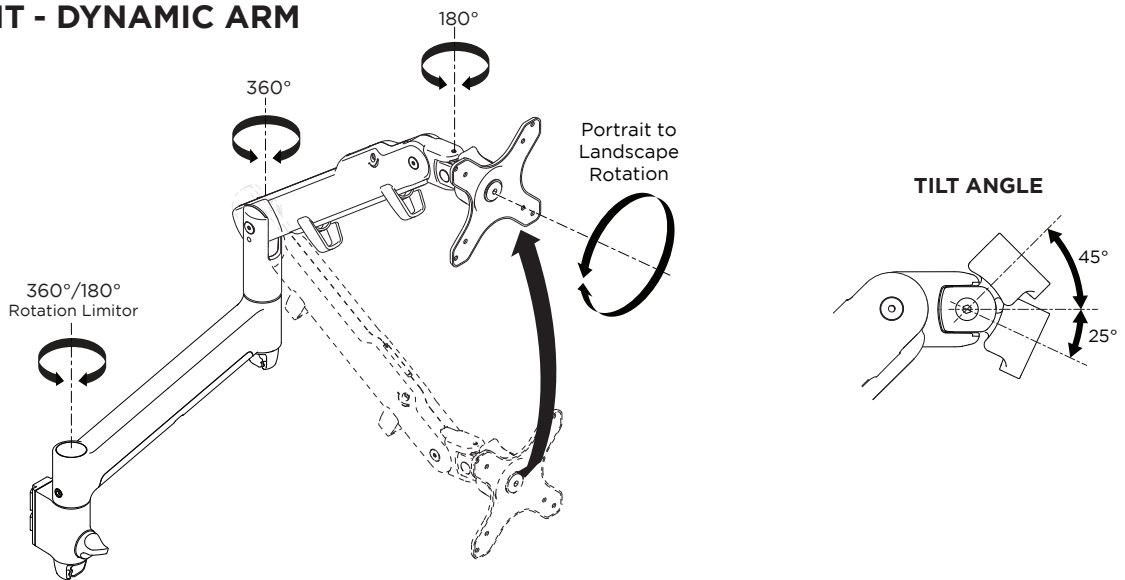

DIMENSIONS - DYNAMIC ARM ON 135 POST

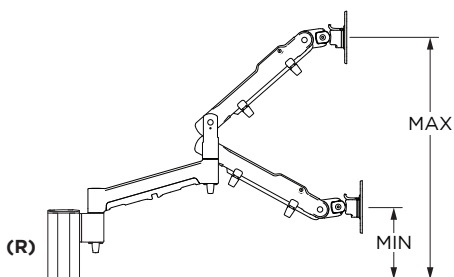

| HEIGHT ON 135 POST *C CLAMP INCREASES MINIMUM HEIGHT ON POST BY 26MM (1") | MIN | MAX | RANGE (R) |
|--|-------------------|--------------------|--------------------|
| | 132mm* (5.20") | 500mm* (19.68") | 368mm* (14.49") |

DIMENSIONS - DYNAMIC ARM ON POST

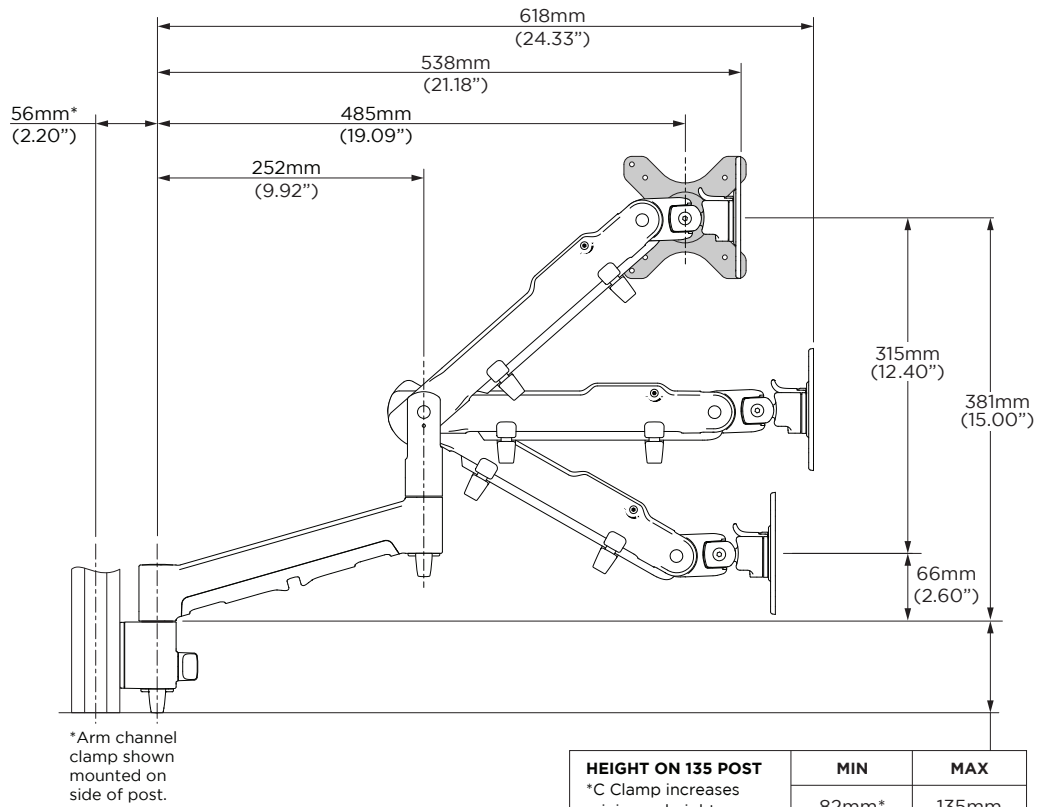

| HEIGHT ON 135 POST | MIN | MAX |
|--|---------------|---------------|
| *C Clamp increases minimum height on post by 26mm (1") | 82mm* (3.23") | 135mm (5.31") |

DIMENSIONS - DYNAMIC ARM ON POST POST SIDE ATTACHMENT

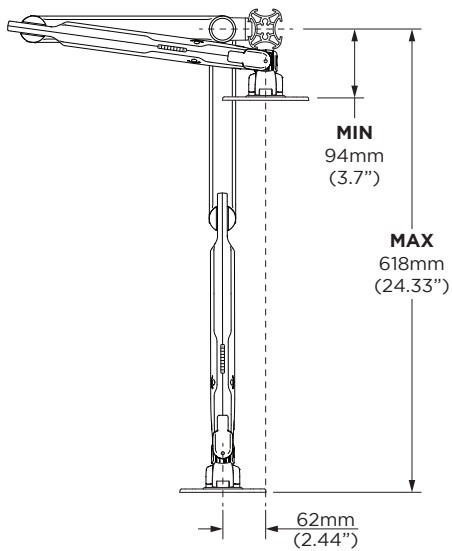

POST FRONT ATTACHMENT

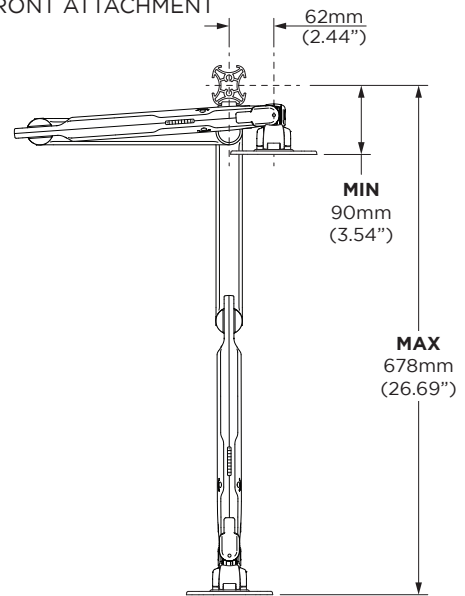

DIMENSIONS - TRAY ON DYNAMIC ARM

TILT ADJUSTMENT

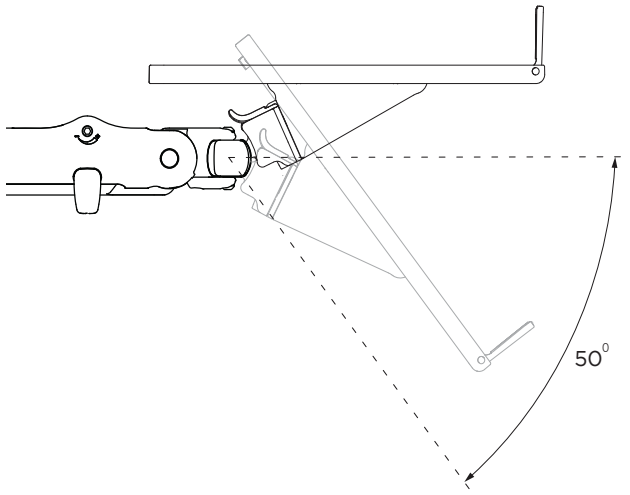

DISTANCE FROM PIVOT

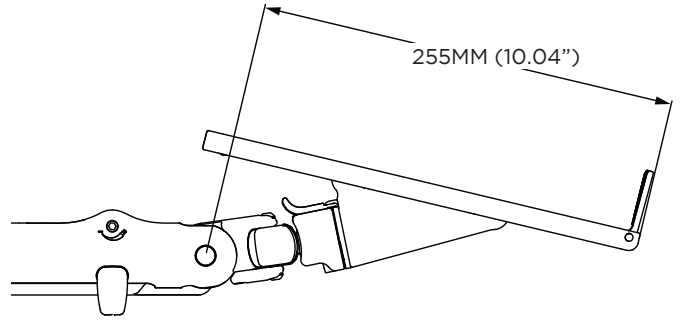

TRAY DIMENSIONS

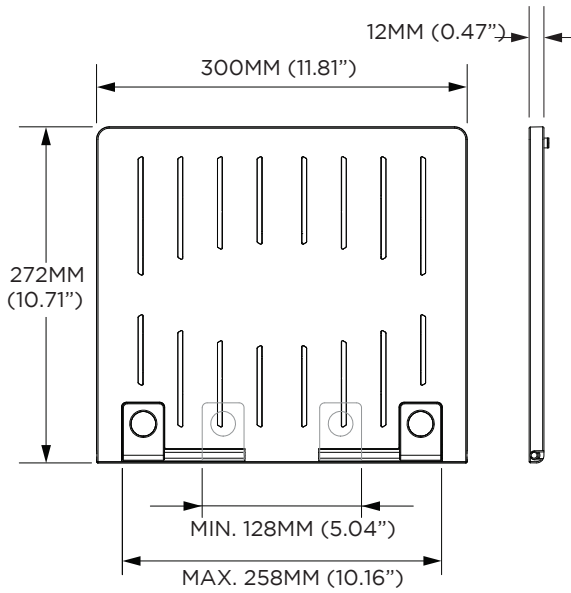

FINE ADJUSTMENT

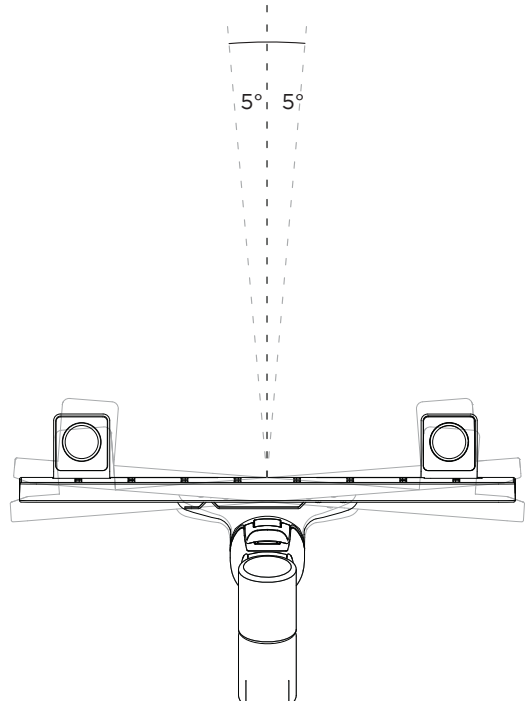

DIMENSIONS - VESA HEAD

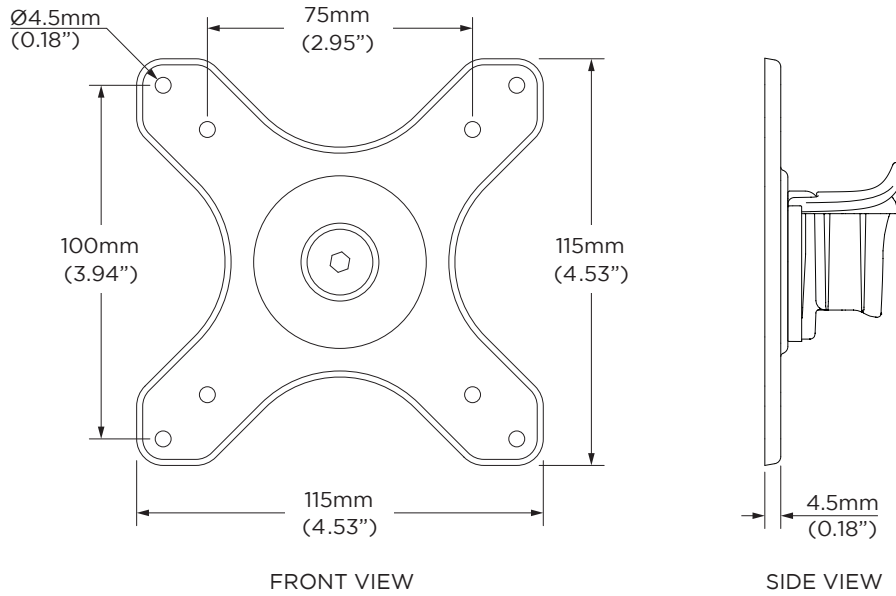

DESK FIXING OPTIONS

Below are the fixing options available for this solution. For more information and detailed specifications for these products please see the separate Technical Specifications available on the Atdec website.
 Note: Chosen desk fixing must be added to this solution code when ordering.

BOLT THROUGH AWM-FB

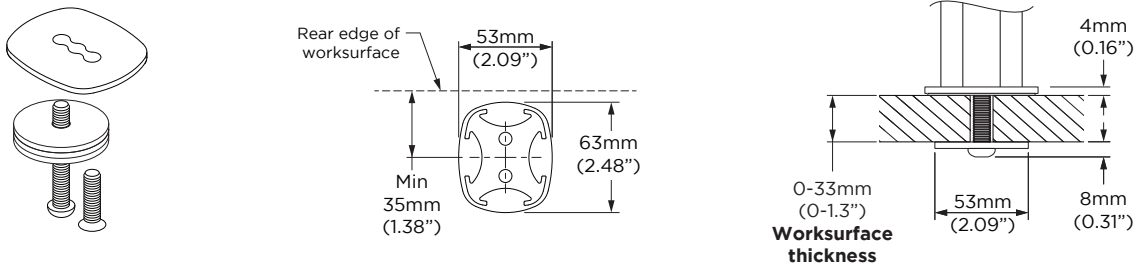

C CLAMP AWM-FC

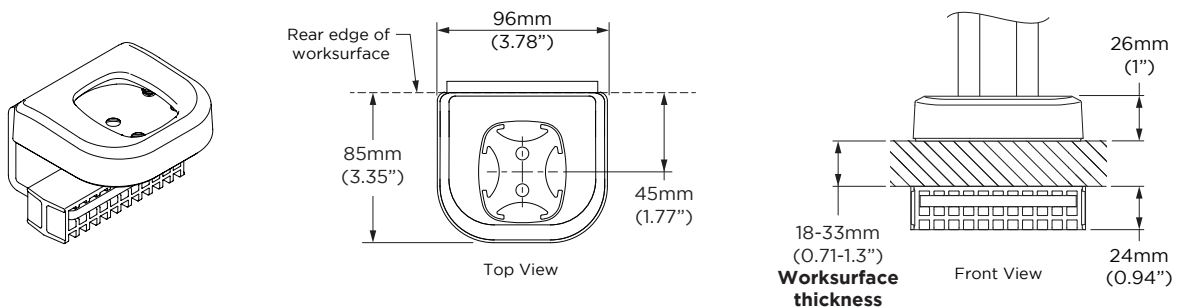

F CLAMP AWM-FF

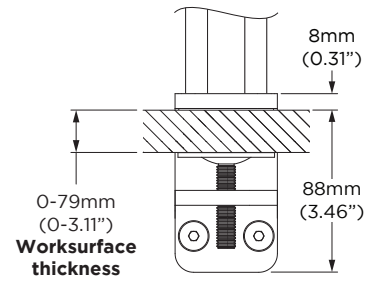
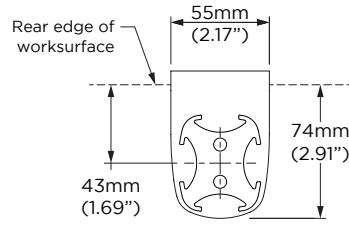
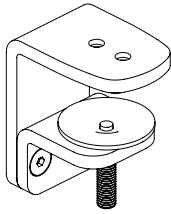

HEAVY DUTY F CLAMP AWM-FH

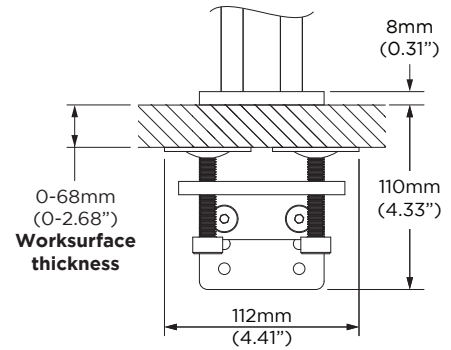
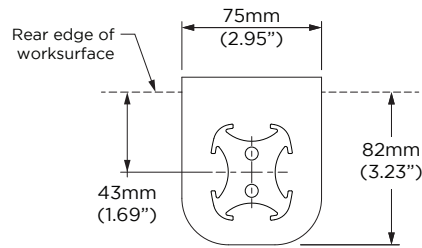
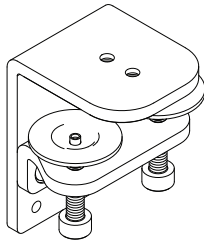

GROMMET CLAMP AC-GC

